



TRANSFRIG

R 500/600



R500T/R600T

- ◆ Over road only condenser



R500TE/R600TE

- ◆ Over road with electric standby condenser



- ◆ Slim-line
- ◆ Light weight
- ◆ Improved load volume
- ◆ Aero dynamic
- ◆ Robust Construction
- ◆ UV resistant



R500T/R500TE

- ◆ Single fan evaporator

R600T/R600TE

- ◆ Dual fan evaporator



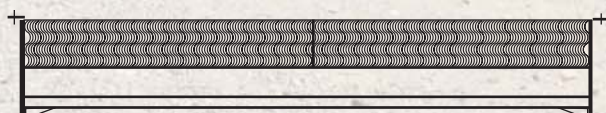
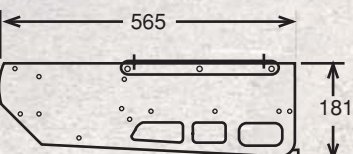
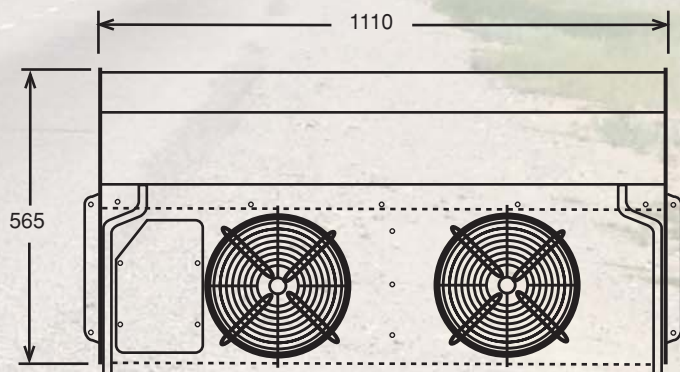
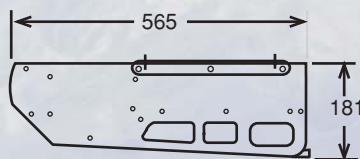
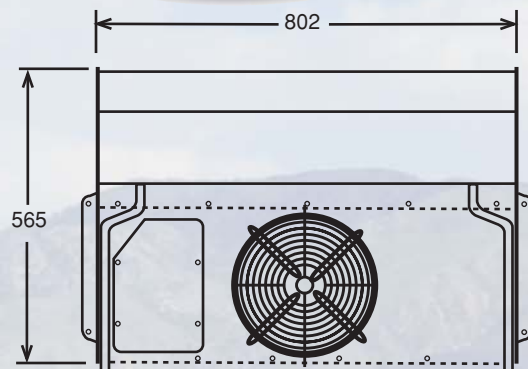
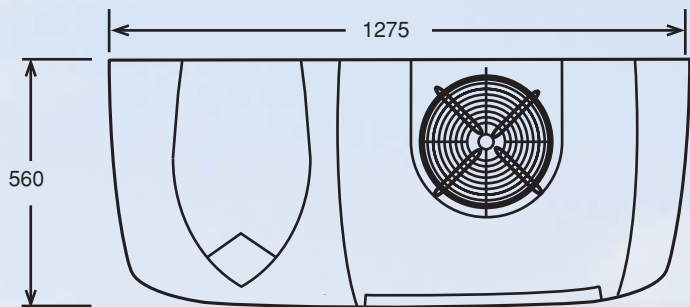
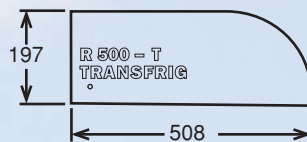
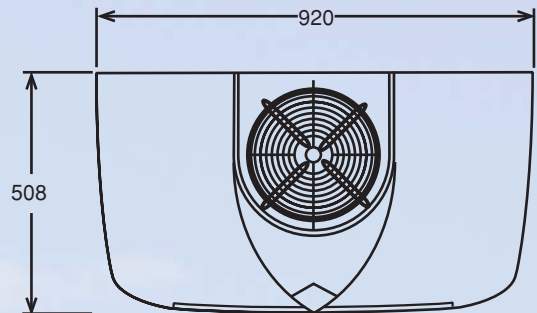



TRANSFRIG

◆ Application

The refrigeration system will refrigerate insulated bodies as tabulated.

Models	Approximate maximum body lengths @ given box temperatures		
	0°C	-18°C	-25°C
R500	3,2m	2,7m	2,3m
R600	4,2m	3,8m	3,2m

Note: In order to ensure the correct application, ambient temperature, body insulation and number of door openings must be taken into consideration. Please consult your Transfrig dealer before final selection.

◆ General design concept

The Transfrig "R" series are split two-piece units for fresh applications on LDV's, small trucks and panel vans.

The roof or bulkhead mount condenser frame is manufactured from epoxy powder coated stainless steel and the evaporator from aluminium and stainless steel.

◆ Options

Truck engine driven only or truck engine with electric standby. Over road refrigeration is by means of a compressor driven directly off the vehicle crankshaft and is available in 12 or 24 volts. Electric standby is available with a choice of 220v 1 phase or 380v 3 phase.

◆ Electric standby motor

R500 – 220/1Phase 50 hz 2,2kW
R600 – 380/3Phase 50 hz 2,2kW

◆ Compressor

R500 – 7 cylinder 130cm³
R600 – 7 cylinder 150cm³

◆ Airflow

A constant airflow is provided by electric evaporator fans.

R 500/600

◆ Defrost

Thermostatically controlled hot gas defrost.

◆ Simple operations

The required temperature is simply set on the thermostat. Initiating refrigeration and changing from over road to electric drive is all controlled from the in-cab control panel.

◆ Ozone friendly refrigerant

Zero ODP R134a.

◆ Capacities

Models	CAPACITY @ 30°C ambient		Evaporator discharge velocity m/s	Airflow volume m ³ /hour
	-20°C Watt	0°C Watt		
R500 Road	1508	2338	5,5	1400
R500 Electric	878	1508		
R600 Road	1818	3121	6,1	2185
R600 Electric	1092	1818		

◆ Weight (Including installation kit)

Units	Weight
R500T	65kg
R500TE	115kg
R600T	70kg
R600TE	120kg

Contact

Transfrig Victoria
548 Clayton RD
Clayton
Victoria 3168
Australia

Tel 03 9551 6997
Fax 03 9551 6998
Mobile 0423 600 644

Email venterdi@bigpond.net.au
Website www.transfrig.co.za

